



Fonderie Sime S.p.A. - Via Garbo, 27 - 37045 Legnago (VR) - [www.sime.it](http://www.sime.it)  
Tribunale Verona 13531 - R.E.A. VR 171357 - C.C.P. 19423375 - N° Mecc. VR 014435  
Capitale Sociale Euro 5.521.200 int. versato - Codice Fiscale/Partita IVA n. IT 01275930236

Comfort Ambiente - Via Garbo, 27 - 37045 Legnago (VR)

Tel +39 0442 631111 - Fax Servizio Commerciale: Italia +39 0442 631291 - Estero +39 0442 631293

Fax Servizio Tecnico +39 0442 631292 - Fax Ufficio Acquisti +39 0442 631292 - Fax Amministrazione +39 0442 631336

8104991 MURELLE HE 110 R ErP

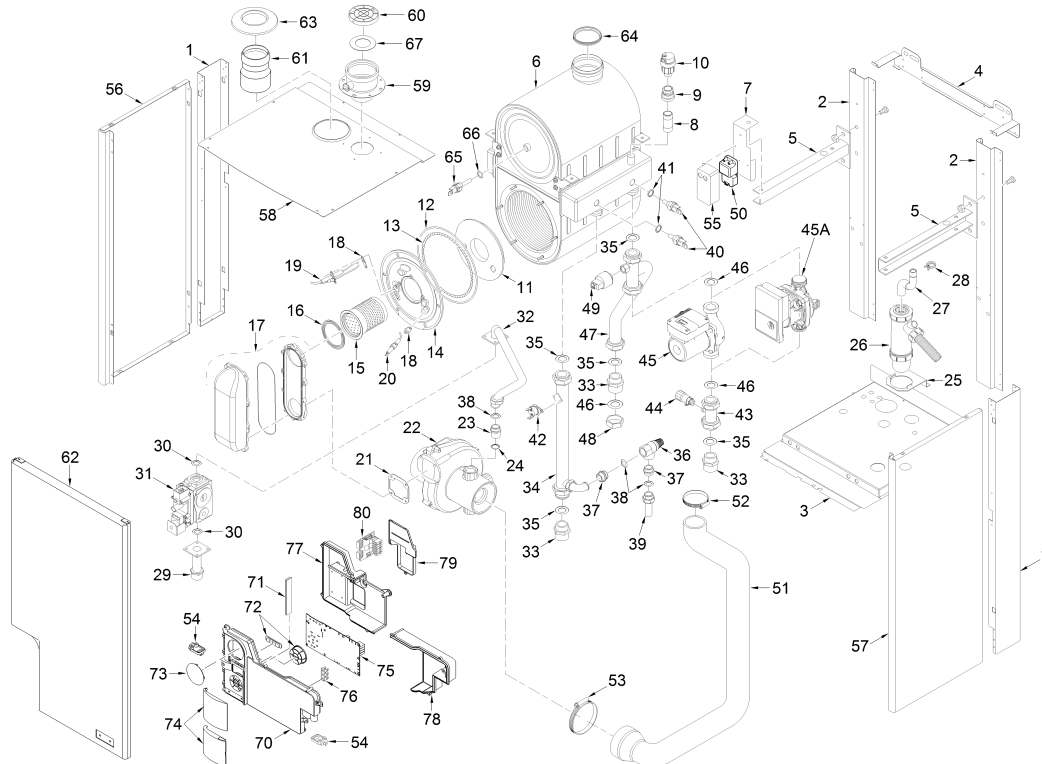

Kit compensatore idraulico / sicurezza ISPSEL (Italia)

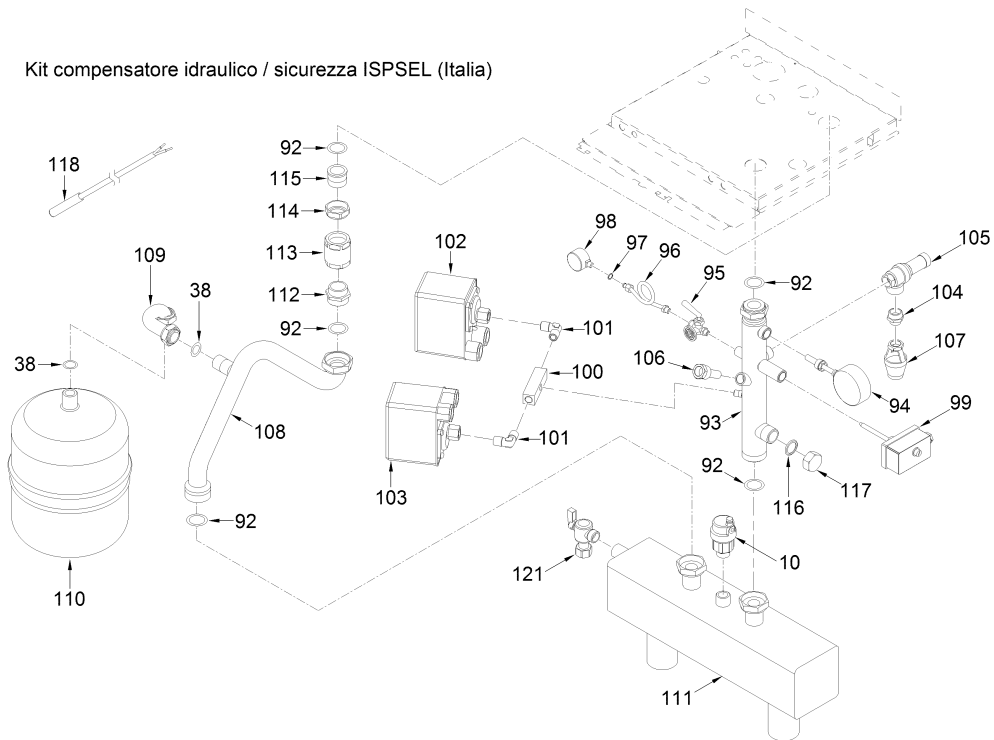

UK - Hydraulic compensator kit (Export)  
 FR - Kit compensateur hydraulique (Etranger)  
 ES - Kit compensador hidráulico (Extranjero)

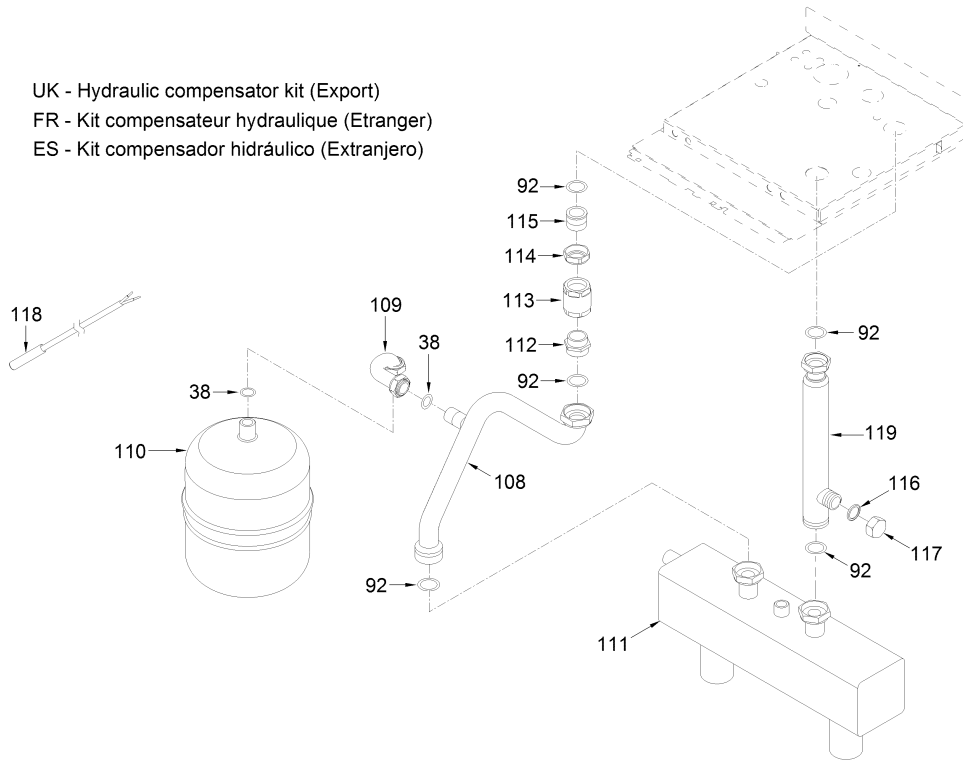

Position	Code	Description	Where used
001	6138555	Right/left hand side frame part	
002	6256731	Main exchanger rear support	
003	6138896	Frame assembly lower side	
004	6138715	Frame assembly upper support	
005	6294823	Main exchanger support	
006	6278915	Main exchanger body	
007	6189562	Ignition transformer panel brac	
008	6070815	Extension MM 3/4"	
009	6104710	Reduction	
010	6013106	Automatic air vent 1/2"	
011	6269009	Main exchanger door insulation	
012	6278967	Combustion chamber O-ring	
013	6278968	Glass fibre sealing cord	
014	6278854	Main exchanger door	
015	6278320	Premix burner	
016	6174823	Gasket for burner flange	
017	6278880	Air-gas full hose	
018	6174809	Gasket for ignition electrode	
019	6221622	Ignition electrode	
020	6221623	Ionisation electrode	
021	6174816	Gasket for fan flange	
022	6261413	Fan	
023	6274185	Burner nozzle	MET
023A	6274186	Burner nozzle	GPL
024	6226407	O-ring 130 ø 22,22x2,62	
025	6010822	Water trap bracket	
026	6277201	Water trap	
027	6034155	Condensate drainage pipe	
028	2051123	Clamp diam. 24,2	
029	6226892	Gas inlet pipe	
030	2030223	Gasket NPR 24x35x4	
031	6238503	Gas valve	
032	6226969	Pipe connecting gas valve-mixer	
033	6120529	Nipple 1"1/4 x 1"1/2	
034	6216245	C.H. flow pipe	
035	2030256	Gasket diam.26x38x3	
036	6040210	Pressure relief valve 3/4" 5 ba	
037	6120502	Nipple 3/4"x3/4" OT	
038	2030249	Gasket Ø 24x17x3	
039A	6142516	Pipe diam. 22x1"x50	
040	6231351	Plunged sensor	
041	6022010	Sensor gasket	
042	6146722	95°C safety stat	
043	6277941	Pump connecting pipe	
044	6017211	Manual air vent 1/4"	
045A	6272324	Circulating pump	

046	2030254	Gasket Ø 33x44x3
047	6277942	Pump connecting pipe
048	6229505	Plug 1-1/2"
049	6273610	Water pressure transducer
050	6098350	Ignition transformer
051	6001155	Pipe Ø 60
052	2051200	Hose clamp Ø 50-70
053	2051202	Hose clamp Ø 90-110
054	6302000	Plastic pin
055	6159710	Ignition transformer protection
056	6242235	Casing left hand side panel
057	6242135	Casing right hand side panel
058	6010861	Upper protection shield
059	6083062	Flue inlet flange Ø 80
060	6190001	Intake terminal Ø 80
061	6296527	Reducer DN 80-100"
062	6304233	Casing front panel
063	6230402	External ring for pipe diam.80
064	6248829	Air inlet / smoke outlet gasket
065	6277131	Probe NTC D.4X47
066	6226440	O-ring diam. 9,25x1,78
067	6028692	Air diaphragm Ø 79/46
070	6304700	Control panel
071	6305160	Guidelight with led
072	6305120	Kit Rubber button
073	6247327	Cap for time programmer
074	6304890	Flap door assembly
075	6301480	Main PCB
076	2211610	Earth faston
077	6305000	Cover
078	6305010	connection cover
079	6305020	Time programmer cover
080	6301465	PCB expansion
092	2030206	Piracriten gasket Ø 33,5x45x2
093	6291966	ISPESL safeties pipe
094	6146004	Thermometer 0-120°C
095	6216606	Manometer cock ISPESL 1/4"
096	6216650	Manometer cock connection pipe
097	2030225	Gasket Ø 5,5x11x2
098	6217051	Manometer 0/10 bar
099	6001409	H.L. stat 100°C
100	6291981	Water pressure switch block
101	6291982	90° MM G 1/4" curve
102	6037551	Min.m.reset water press.switch
103	6037550	Safety m.reset water pres.switc
104	2040252	Nipple 1" x 3/4"
105	6042203	Pressure relief valve 3/4"X1" 4
106	5064600	Bulb holder 1/2" L=50
107	6269402	Tundish
108	6227440	C.H. return pipe
109	6227683	Pipe connecting D.H.W. expans.
110	6245108	D.H.W. expansion vessel I. 8
111	6216313	Hydraulic compensator
112	6120527	Nipple 1"1/2 X 1"1/4
113	6238304	Check valve
114	6271810	Pipe fitting 1"1/2
115	6120541	Pipe fitting 1"1/4"
116	2030257	Gasket diam. 30x22x3
117	6229502	Plug 1" F. OT
118	6231331	D.H.W. tank sensor
119	6291967	C.H. flow pipe
701	6127214	Main cable L=1500
702	6319169	3 pole cable connector
703	6319162	4 pole cable connector
705	6319164	9 pole cable connector
706	6319168	14 pole cable connector
707	6319166	4 pole cable connector
708	6316202	Connector 4 poli
709	6316203	Connector 4 poli CN4
710	6316204	Connector 8 poli CN7
711	6186587	Ionisation electrode cable
712	6319165	5 pole cable connector
713	5185141	Conversion kit to LPG
715	6316200	Connector 2 poli
716	6316201	Connector 4 poli
717	5197197	Complete control panel
718	6141902	Plug Wieland ST 18/5 S

719	6325618	5 pole cable connector
721	6277103	Thermo-fuse 318°C